

The T300 mobile peristaltic pumps are designed for a wide range of applications across all industries. Available with petrol, diesel and electric motors, the advantages offered by this pump make it ideally suited for pollution clean-up, oil skimmer offloading and tank cleaning applications.

- Dry self priming to 9.5 metres
- Ideal for long fibre media and solids handling upto 12mm
- Dry running without damage
- Compact and portable design
- Available with diesel, electric or petrol drive options
- Flowrates upto 18m³/hr
- Max pumping pressure 1.5 bar
- Pumping viscous media
- 2" (50mm) connections

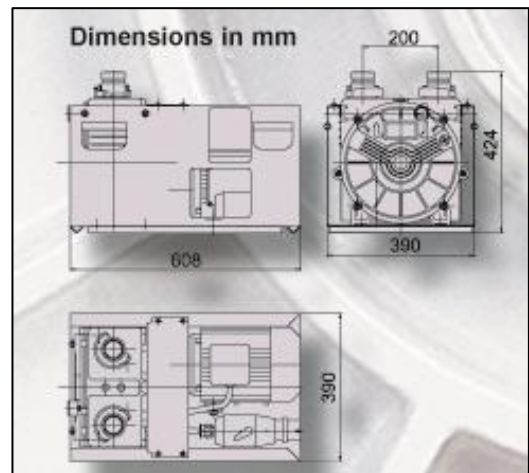
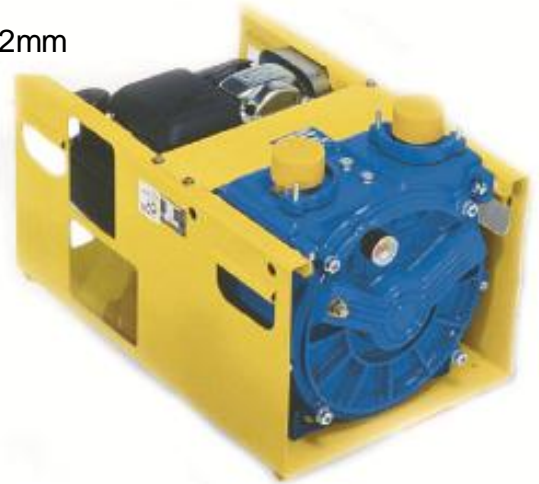

Specifications

Code	Drive	Max Flow Rate	Pressure Bar	Weight Kg
T300D	Hatz Diesel Engine	18m ³ /hr	1.5	70
T300E	Electric Motor 3kW	18m ³ /hr	1.5	66
T300G	Honda Petrol Engine	18m ³ /hr	1.5	59